

TUTORIAL 3823

# Switching Video Using Analog Switches

Jun 23, 2006

*Abstract: Although digital video is increasing in popularity, analog video remains in use in many applications. This article describes standard analog video formats and ways to switch between analog video sources.*

## Introduction

Historically, RS-170 was the original black-and-white video standard in which video is divided into frames, with typical frame rates of 30 (U.S.) or 25 (Europe) frames per second. Broadcast television divides each frame into two interlaced fields. For North American television, a horizontal rate of 15750 lines was displayed in 1/30 of a second using two fields of interlaced video per frame. By convention, black is the most negative active video signal with sync tip going below black. The DC levels for various portions of the signal are shown in **Figure 1**.

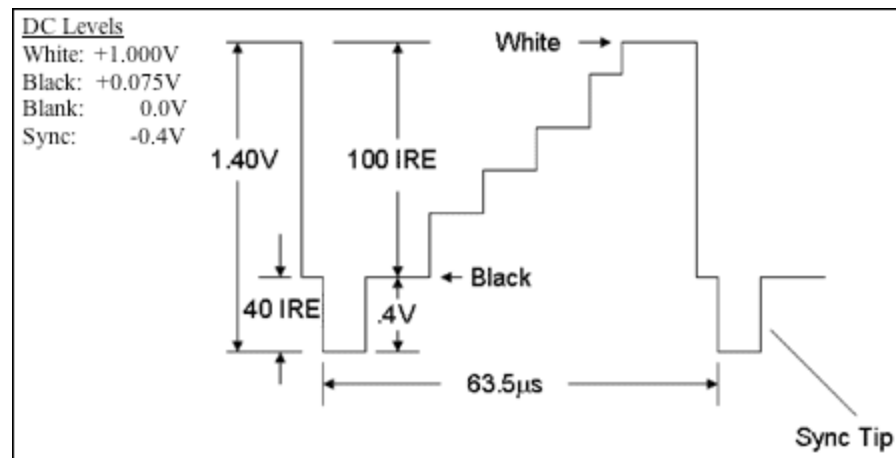

Figure 1. Black-and-white signal DC levels.

White level to black level was defined to be 100 IRE units for the active video portion, and white to sync tip was therefore 140 IRE units. If the signal was attenuated, the ratio of white to black and white to sync tip remained constant; whether the signal was attenuated or amplified, the value of the white to sync tip signal was 140 IRE units.

Today's composite video baseband signal (CVBS) is a derivative of RS-170 with white to sync tip nominally set to 1.0V (white at +0.714, blank at 0V, and sync tip at -0.286). This could be considered as an RS-170 signal attenuated by 71%, as all IRE values still hold. The National Television Standards

Committee (NTSC) system juggled some horizontal and vertical values and very cleverly fit bandwidth-reduced color information into essentially the same baseband signal. Because the black-and-white information was already being transmitted, which was necessary for early black-and-white compatibility, the black-and-white signal needed to remain part of any color system. This information has become known as Y, or luminance information. Y consists of the sum of RGB signals<sup>1</sup>.

NTSC, and later PAL and SECAM, makes use of similar properties. Because Y was already being broadcast, R-Y, and B-Y are needed to create RGB. RGB can be extracted from the components, with a little algebraic manipulation as follows:

$$Y = R + G + B, R = Y + (R - Y), G = Y + (G - Y), B = Y - R - B$$

These manipulations can be done with sums and differences in a few simple circuits. For NTSC and PAL, the R-Y (U), and B-Y (V) information is modulated to permit the UV signals to be recovered easily from the baseband signal. When observing a color NTSC signal at baseband from a DVD player, for example, the signal looks very much like the RS-170 signal. However, we can see the color-burst frequency showing a number of "ring cycles" of approximately 3.58MHz/4.43MHz right after the sync tip (back porch). PAL signals look quite similar, with slightly different H and V sync and color-burst frequencies. The amplitude is nominally 1.0V from white to sync tip.

By convention, the nominal impedance for video cables is 75Ω. RG-59/RG-6 are the standard cables for interconnecting video devices, usually with RCA connectors for composite video. In Europe, CVBS is found on the SCART connector, which incorporates CVBS and audio signals.

## Switching CVBS

The bandwidth of CVBS signals is limited to < 6.5MHz for all systems. Because the driving point impedance is low and bandwidth is limited, most analog CMOS switches today can easily handle the task. The signal is below ground, and the designer may use capacitive coupling and then clamp the signal for black level. If care is not taken, sync tip may be lost along with color-burst reference. By convention, the 1.0V signal may vary ±6dB, so this signal may be as large as 2.0V<sub>P-P</sub>, with the sync tip at approximately -600mV. The designer may choose an amplifier with ±5.0V supplies bias up the switches to prevent problems. If the signal is to be passed on again to another CVBS input, then the designer will almost assuredly use the bipolar supply method<sup>2</sup>. If the signal remains on the same board and is used for internal display, then the cheaper bias scheme may be used.

## Application 1—CVBS with Buffered Output

Assuming there are +5 and -5V supplies available, a video op amp is almost always required to do the buffering. The CVBS signal is applied to the noninverting input. The op amp is usually set to +6dB gain so the signal is amplified 2:1, and then a series 75Ω resistor is inserted to properly match the impedances. Most times, the output is AC-coupled through a capacitor. CMOS analog switches perform best when the output is terminated at a reasonably low impedance. Any capacitance across the switch is shunted to ground by the input resistance. Because the CVBS must be terminated in 75Ω, it may be desirable to terminate the circuit in a slightly higher value than 75Ω. If a 300Ω resistor is used as a GND for the noninverting op amp, then using a 95Ω resistor the input impedance will be nearly a perfect match to 75Ω. If the analog switch has an R<sub>ON</sub> value of 35Ω, there will be a slight loss of approximately 1.0dB. The loss can be accommodated by adjusting the gain of the op amp slightly. If the switch were of higher or lower R<sub>ON</sub>, the gain could be adjusted accordingly. Because the video op amp has nearly zero impedance, its output can also drive other circuits simultaneously. It is not desirable to eliminate the resistor or make it very high impedance, as this will leave the video without termination and it may radiate. The use of a 95Ω resistor does not have any adverse effects, and the circuit will be properly

terminated when in use. The switch in **Figure 2** is a complete circuit for a 2:1 video switch with video buffer. It is designed for bipolar operation with a  $\pm V$  supply.

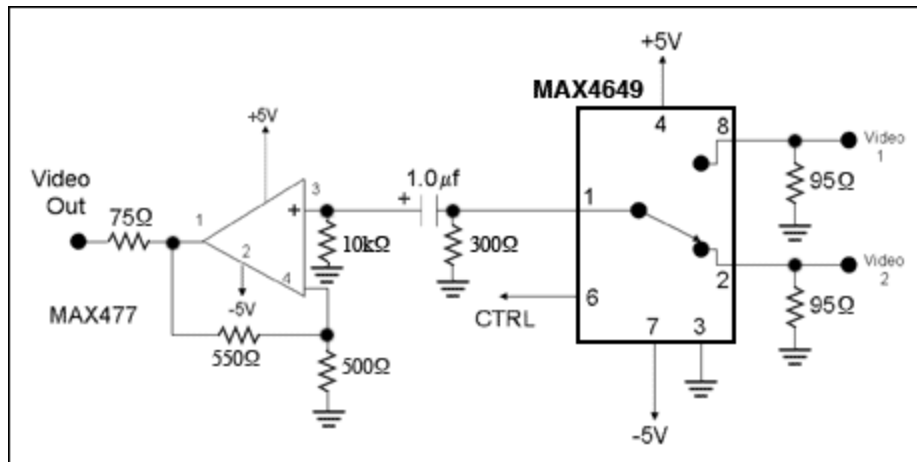

Figure 2. Simple 2:1 CVBS video switcher.

## Higher Performance Analog Video

CVBS is fine for some use, but higher bandwidth recording available on DVD and other devices has created a demand for higher bandwidth connections.

**S-video**, seen primarily on Hi-8 camcorders and DVDs, produces a wider bandwidth picture by sending two signals, the luminance (luma) and chrominance (chroma) signals. Each of these signals is carried on a special DIN connector. The luminance is a wider bandwidth version of the composite signal, but with no color information. The chrominance is the encoded R-Y and B-Y signals. Because the Y signal is now higher bandwidth and the signal does not need to go through special filters to separate the two signals, a much better video signal can be sent. Both the luma and chroma signals can be sent using standard video techniques. Bandwidth should be raised to about 10MHz on the luma signal. The type of circuit in Figure 2 can be used for S-video with two channels (two sets of switches and buffers).

**Component video** is the latest consumer video interface. Unlike VGA signals, component video consists of a Y signal and two color difference signals, instead of RGB. Component video can be stored much more efficiently than RGB and is the native signal obtained from the DVD format. The Y signal is at full bandwidth and contains the sync information. The analog signals Y Pr Pb need to be conveyed from a source to a monitor. The following application shows a monitor with two inputs and one buffered set of outputs using the new MAX4887 switch.

## Application 2—Wide-Bandwidth Component Video with Buffered Output

Component video consists of three analog signals: Y, Pr, and Pb. The Y signal is at full bandwidth. In this application, the new MAX4887 triple video switch is selected for its excellent bandwidth and low insertion loss. As in the previous application, a single 5V supply is used and outputs are buffered, but the circuit is capacitively coupled to the switch and the video op amp. The MAX4887 has more than enough bandwidth and, with the effective 250Ω load, it will have nearly zero loss. To pass the low-frequency sync signals, it is necessary to use a 100μF capacitor. In addition, a 0.01μF ceramic capacitor is placed in parallel to improve the high-frequency response. The **Figure 3** circuit shows one channel. The MAX4887 has three high-frequency switches, and the input/output circuit should be replicated two

more times using the other two switches for a complete design. It is also possible to use the MAX4887 without a buffer.

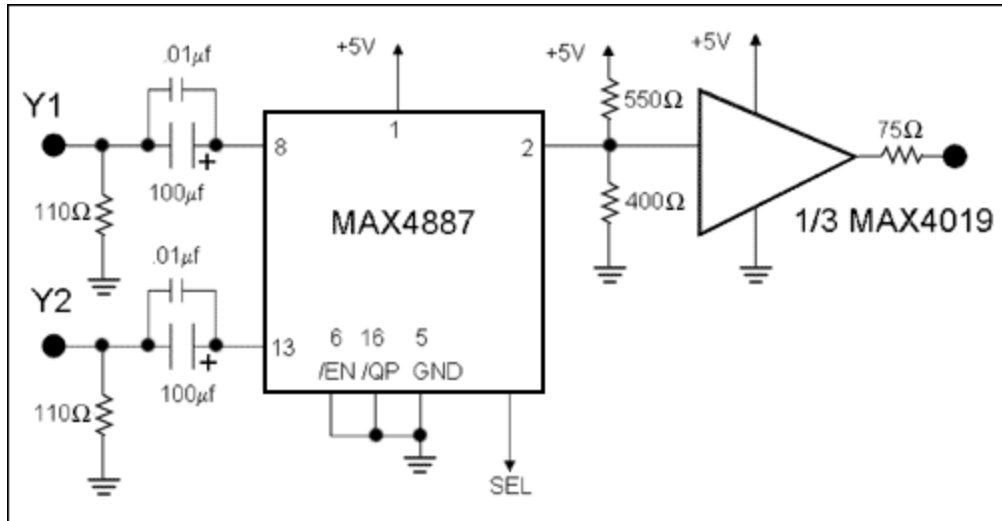

Figure 3. Wide-bandwidth component video design showing only one channel.

The MAX4887 has a series  $R_{ON}$  of only about  $5\Omega$ . The  $1k\Omega$  resistor at the input assures the input is not floating and provides a bit of return loss matching. The total loss for the switch and matching resistor is  $0.6dB$ . This small loss is generally considered insignificant. As with the previous diagram, only one switch is shown in **Figure 4**. For component or RGB video, three identical circuits would be used, all of which are contained in the MAX4887.

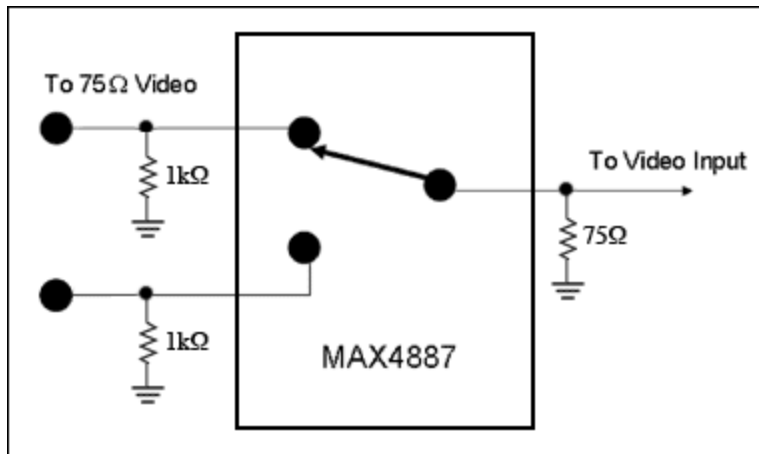

Figure 4. MAX4887 used in a VGA RGB video design.

The Figure 4 circuit is appropriate for VGA RGB video. If the video signal had peak values that were significantly negative, then the MAX4887 would not be the appropriate choice, unless the input ESD protection were prevented from conducting. This would happen if the signal were more negative than  $-0.3V$ . If a negative voltage supply is available, then it is possible to operate the switch from  $+3.3V$  and  $-1.5V$ . Because the switch barely uses any current, its negative rail (normally GND) can be biased to  $-1.5V$ . The switch would then function normally, with the exception of the select pin. A pnp-inverting transistor with its emitter at  $+3.3V$  and a collector resistor tied to  $-1.5V$  solves the voltage-level issues.

## Conclusion

The pervasive nature of video has created a need to be able to handle many different video sources. Because of the nature of the video signal, either dual supplies or capacitive coupling must be used. Maxim offers a number of analog switches and video op amps to match either method, simply and economically.

### Notes:

<sup>1</sup>Strictly speaking, there should be scale factors for RGB (e.g., white = (.30 x R) + (.59 x G + (.11 x B))

<sup>2</sup>In most cases, the CVBS signal is taken in and then buffered as an output (e.g., video in/video out on a TV or VCR).

### Also See:

Application note 734, "[Video Basics.](#)"

Application note 1184, "[Understanding Analog Video Signals.](#)"

Related Parts		
<a href="#">MAX4079</a>	Complete Audio/Video Backend Solution	<a href="#">Free Samples</a>
<a href="#">MAX4649</a>	45 Ohm SPDT Analog Switch in SOT23-8	<a href="#">Free Samples</a>
<a href="#">MAX477</a>	300MHz High-Speed Op Amp	
<a href="#">MAX4887</a>	Triple Video Switch	<a href="#">Free Samples</a>

---

### More Information

For Technical Support: <http://www.maximintegrated.com/support>

For Samples: <http://www.maximintegrated.com/samples>

Other Questions and Comments: <http://www.maximintegrated.com/contact>

---

Application Note 3823: <http://www.maximintegrated.com/an3823>

TUTORIAL 3823, AN3823, AN 3823, APP3823, Appnote3823, Appnote 3823

Copyright © by Maxim Integrated Products

Additional Legal Notices: <http://www.maximintegrated.com/legal>