

Trench gate field-stop, 650 V, 20 A, M series low-loss IGBT

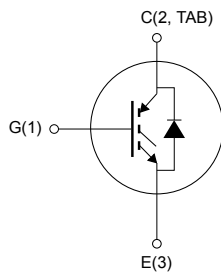

NG1E3C2T

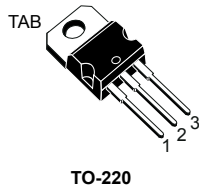

Features

- High short-circuit withstand time
- $V_{CE(sat)} = 1.55 \text{ V (typ.) @ } I_C = 20 \text{ A}$
- Tight parameters distribution
- Safer paralleling
- Low thermal resistance
- Soft and very fast recovery antiparallel diode

Applications

- Motor control
- UPS
- PFC
- General-purpose inverters

Description

This device is an IGBT developed using an advanced proprietary trench gate field-stop structure. The device is part of the M series IGBTs, which represent an optimal balance between inverter system performance and efficiency where the low-loss and the short-circuit functionality is essential. Furthermore, the positive $V_{CE(sat)}$ temperature coefficient and the tight parameter distribution result in safer paralleling operation.

Product status link

[STGP20M65DF2](#)

Product summary

| | |
|------------|--------------|
| Order code | STGP20M65DF2 |
| Marking | G20M65DF2 |
| Package | TO-220 |
| Packing | Tube |

1 Electrical ratings

Table 1. Absolute maximum ratings

| Symbol | Parameter | Value | Unit |
|----------------|---|------------|------|
| V_{CES} | Collector-emitter voltage ($V_{GE} = 0$) | 650 | V |
| I_C | Continuous collector current at $T_C = 25\text{ °C}$ | 40 | A |
| | Continuous collector current at $T_C = 100\text{ °C}$ | 20 | A |
| $I_{CP}^{(1)}$ | Pulsed collector current | 80 | A |
| V_{GE} | Gate-emitter voltage | ± 20 | V |
| I_F | Continuous forward current at $T_C = 25\text{ °C}$ | 40 | A |
| | Continuous forward current at $T_C = 100\text{ °C}$ | 20 | A |
| $I_{FP}^{(1)}$ | Pulsed forward current | 80 | A |
| P_{TOT} | Total dissipation at $T_C = 25\text{ °C}$ | 166 | W |
| T_{STG} | Storage temperature range | -55 to 150 | °C |
| T_J | Operating junction temperature range | -55 to 175 | °C |

1. Pulse width limited by maximum junction temperature.

Table 2. Thermal data

| Symbol | Parameter | Value | Unit |
|------------|--|-------|------|
| R_{thJC} | Thermal resistance junction-case IGBT | 0.9 | °C/W |
| R_{thJC} | Thermal resistance junction-case diode | 2.08 | °C/W |
| R_{thJA} | Thermal resistance junction-ambient | 62.5 | °C/W |

2 Electrical characteristics

$T_C = 25\text{ °C}$ unless otherwise specified

Table 3. Static characteristics

| Symbol | Parameter | Test conditions | Min. | Typ. | Max. | Unit |
|---------------|--------------------------------------|--|------|------|------|---------------|
| $V_{(BR)CES}$ | Collector-emitter breakdown voltage | $V_{GE} = 0\text{ V}, I_C = 250\text{ }\mu\text{A}$ | 650 | | | V |
| $V_{CE(sat)}$ | Collector-emitter saturation voltage | $V_{GE} = 15\text{ V}, I_C = 20\text{ A}$ | | 1.55 | 2.0 | V |
| | | $V_{GE} = 15\text{ V}, I_C = 20\text{ A}, T_J = 125\text{ °C}$ | | 1.95 | | |
| | | $V_{GE} = 15\text{ V}, I_C = 20\text{ A}, T_J = 175\text{ °C}$ | | 2.1 | | |
| V_F | Forward on-voltage | $I_F = 20\text{ A}$ | | 1.85 | | V |
| | | $I_F = 20\text{ A}, T_J = 125\text{ °C}$ | | 1.65 | | |
| | | $I_F = 20\text{ A}, T_J = 175\text{ °C}$ | | 1.55 | | |
| $V_{GE(th)}$ | Gate threshold voltage | $V_{CE} = V_{GE}, I_C = 500\text{ }\mu\text{A}$ | 5 | 6 | 7 | V |
| I_{CES} | Collector cut-off current | $V_{GE} = 0\text{ V}, V_{CE} = 650\text{ V}$ | | | 25 | μA |
| I_{GES} | Gate-emitter leakage current | $V_{CE} = 0\text{ V}, V_{GE} = \pm 20\text{ V}$ | | | 250 | nA |

Table 4. Dynamic characteristics

| Symbol | Parameter | Test conditions | Min. | Typ. | Max. | Unit |
|-----------|------------------------------|---|------|------|------|------|
| C_{ies} | Input capacitance | $V_{CE} = 25\text{ V}, f = 1\text{ MHz}, V_{GE} = 0\text{ V}$ | - | 1688 | - | pF |
| C_{oes} | Output capacitance | | - | 95 | - | |
| C_{res} | Reverse transfer capacitance | | - | 35 | - | |
| Q_g | Total gate charge | $V_{CC} = 520\text{ V}, I_C = 20\text{ A},$ | - | 63 | - | nC |
| Q_{ge} | Gate-emitter charge | $V_{GE} = 0\text{ to }15\text{ V}$ | - | 15 | - | |
| Q_{gc} | Gate-collector charge | (see Figure 29. Gate charge test circuit) | - | 26 | - | |

Table 5. IGBT switching characteristics (inductive load)

| Symbol | Parameter | Test conditions | Min. | Typ. | Max. | Unit |
|-----------------|------------------------------|--|---|------|------|------------|
| $t_{d(on)}$ | Turn-on delay time | $V_{CE} = 400\text{ V}$, $I_C = 20\text{ A}$, $V_{GE} = 15\text{ V}$, $R_G = 12\ \Omega$ (see Figure 28. Test circuit for inductive load switching) | | 26 | - | ns |
| t_r | Current rise time | | | 10.8 | - | ns |
| $(di/dt)_{on}$ | Turn-on current slope | | | 1409 | - | A/ μ s |
| $t_{d(off)}$ | Turn-off delay time | | | 108 | - | ns |
| t_f | Current fall time | | | 65 | - | ns |
| $E_{on}^{(1)}$ | Turn-on switching energy | | | 0.14 | - | mJ |
| $E_{off}^{(2)}$ | Turn-off switching energy | | | 0.56 | - | mJ |
| E_{ts} | Total switching energy | | | 0.7 | - | mJ |
| $t_{d(on)}$ | Turn-on delay time | | $V_{CE} = 400\text{ V}$, $I_C = 20\text{ A}$, $V_{GE} = 15\text{ V}$, $R_G = 12\ \Omega$, $T_J = 175\text{ }^\circ\text{C}$ (see Figure 28. Test circuit for inductive load switching) | | 28.4 | - |
| t_r | Current rise time | | | 11.2 | - | ns |
| $(di/dt)_{on}$ | Turn-on current slope | | | 1393 | - | A/ μ s |
| $t_{d(off)}$ | Turn-off delay time | | | 107 | - | ns |
| t_f | Current fall time | | | 145 | - | ns |
| $E_{on}^{(1)}$ | Turn-on switching energy | | | 0.3 | - | mJ |
| $E_{off}^{(2)}$ | Turn-off switching energy | | | 0.85 | - | mJ |
| E_{ts} | Total switching energy | | | 1.15 | - | mJ |
| t_{sc} | Short-circuit withstand time | $V_{CC} = 400\text{ V}$, $V_{GE} = 13\text{ V}$, $T_{Jstart} = 150\text{ }^\circ\text{C}$ | | 10 | | - |
| | | $V_{CC} = 400\text{ V}$, $V_{GE} = 15\text{ V}$, $T_{Jstart} = 150\text{ }^\circ\text{C}$ | 6 | | - | |

1. Including the reverse recovery of the diode.
2. Including the tail of the collector current.

Table 6. Diode switching characteristics (inductive load)

| Symbol | Parameter | Test conditions | Min. | Typ. | Max. | Unit | |
|--------------|--|---|------|------|------|------|------------|
| t_{rr} | Reverse recovery time | $I_F = 20\text{ A}$, $V_R = 400\text{ V}$, $V_{GE} = 15\text{ V}$, $di/dt = 1000\text{ A}/\mu\text{s}$ (see Figure 28. Test circuit for inductive load switching) | - | 166 | | ns | |
| Q_{rr} | Reverse recovery charge | | | - | 690 | | nC |
| I_{rrm} | Reverse recovery current | | | - | 13.2 | | A |
| dI_{rr}/dt | Peak rate of fall of reverse recovery current during t_b | | | - | 769 | | A/ μ s |
| E_{rr} | Reverse recovery energy | | | - | 81 | | μ J |
| t_{rr} | Reverse recovery time | $I_F = 20\text{ A}$, $V_R = 400\text{ V}$, $V_{GE} = 15\text{ V}$, $T_J = 175\text{ }^\circ\text{C}$, $di/dt = 1000\text{ A}/\mu\text{s}$ (see Figure 28. Test circuit for inductive load switching) | - | 281 | | ns | |
| Q_{rr} | Reverse recovery charge | | | - | 2010 | | nC |
| I_{rrm} | Reverse recovery current | | | - | 19.6 | | A |
| dI_{rr}/dt | Peak rate of fall of reverse recovery current during t_b | | | - | 370 | | A/ μ s |
| E_{rr} | Reverse recovery energy | | | - | 215 | | μ J |

2.1 Electrical characteristics (curves)

Figure 1. Power dissipation vs case temperature

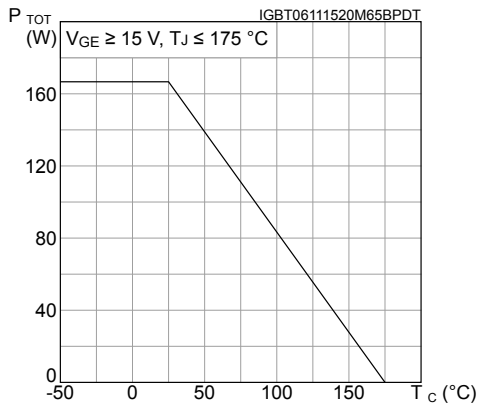

Figure 2. Collector current vs case temperature

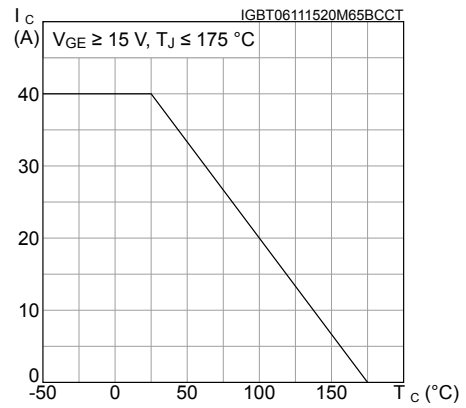

Figure 3. Output characteristics ($T_J = 25\text{ }^\circ\text{C}$)

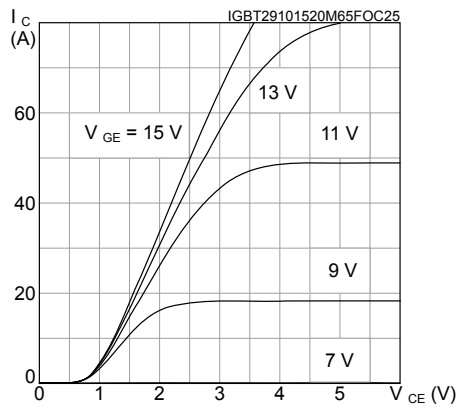

Figure 4. Output characteristics ($T_J = 175\text{ }^\circ\text{C}$)

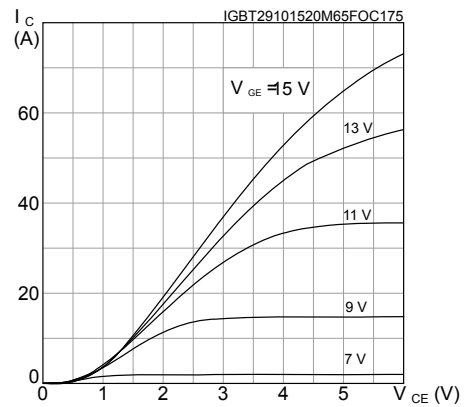

Figure 5. $V_{CE(sat)}$ vs junction temperature

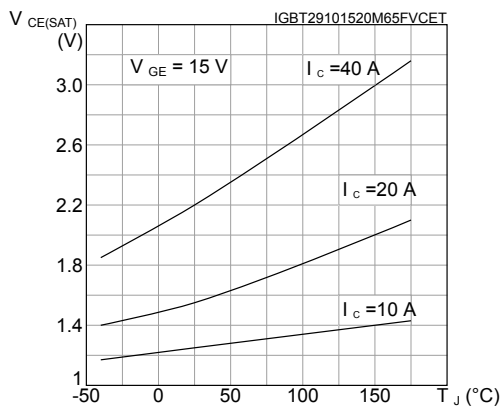

Figure 6. $V_{CE(sat)}$ vs collector current

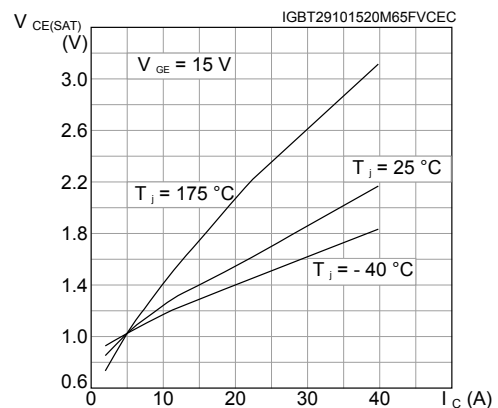

Figure 7. Collector current vs switching frequency

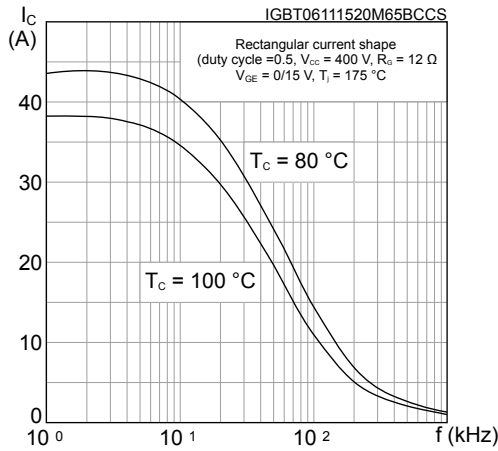

Figure 8. Forward bias safe operating area

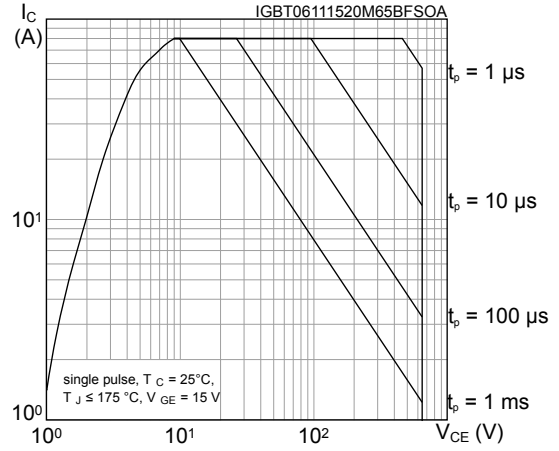

Figure 9. Transfer characteristics

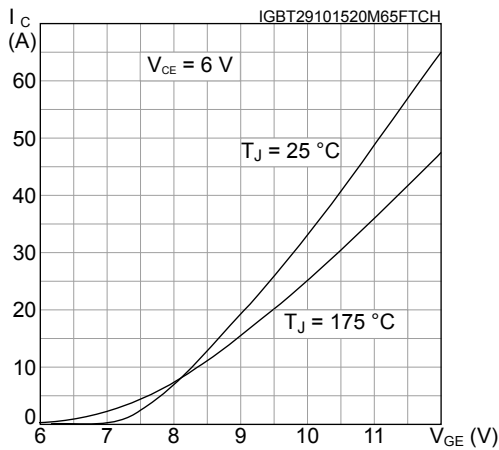

Figure 10. Diode V_F vs forward current

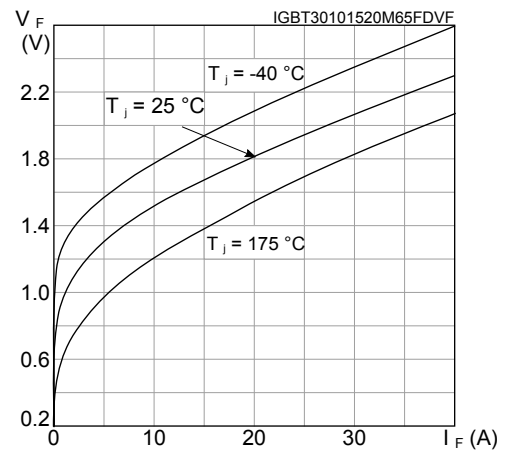

Figure 11. Normalized V_GE(th) vs junction temperature

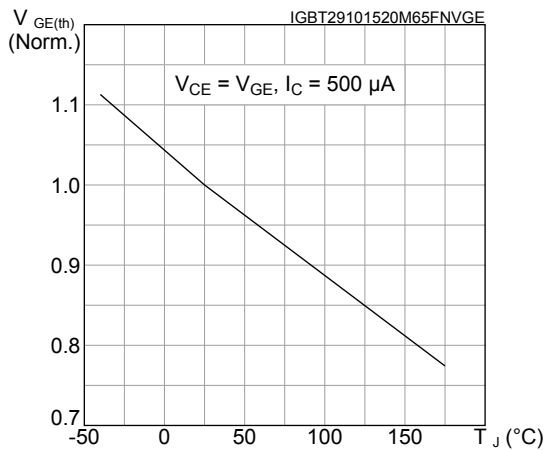

Figure 12. Normalized V_(BR)CES vs junction temperature

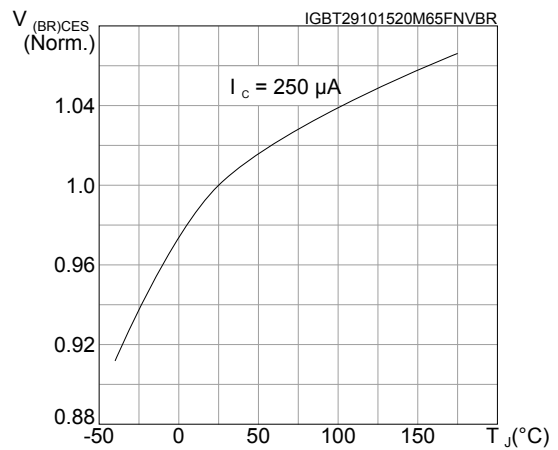

Figure 13. Capacitance variations

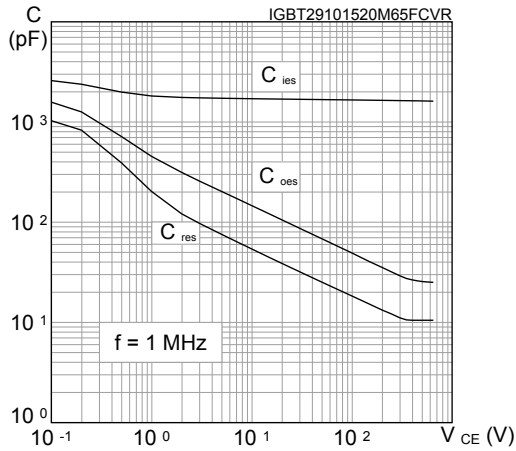

Figure 14. Gate charge vs gate-emitter voltage

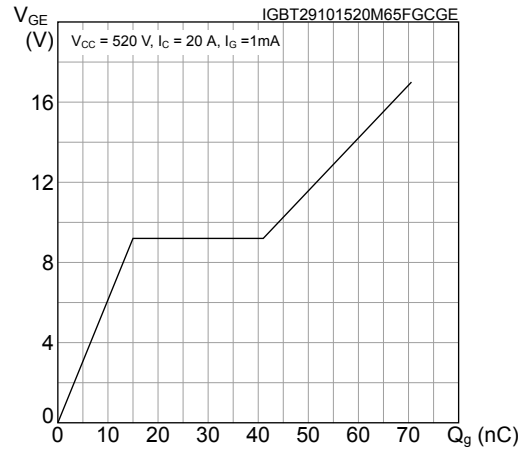

Figure 15. Switching energy vs collector current

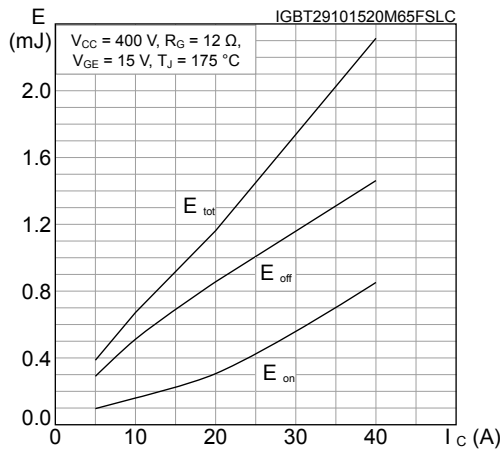

Figure 16. Switching energy vs gate resistance

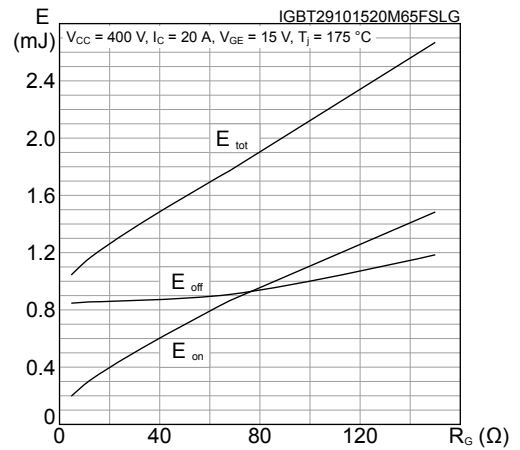

Figure 17. Switching energy vs temperature

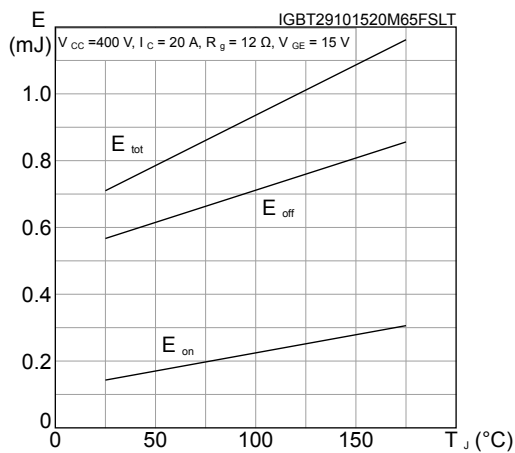

Figure 18. Switching energy vs collector emitter voltage

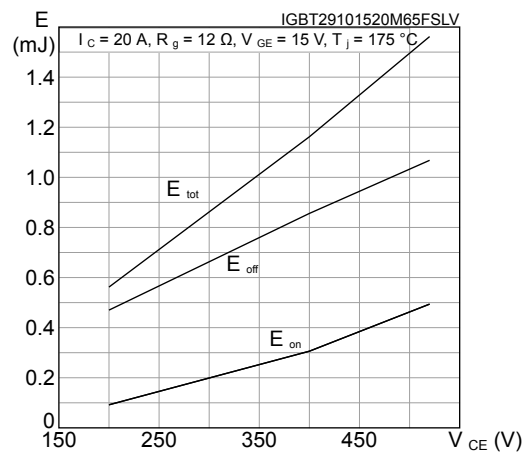

Figure 19. Short-circuit time and current vs V_{GE}

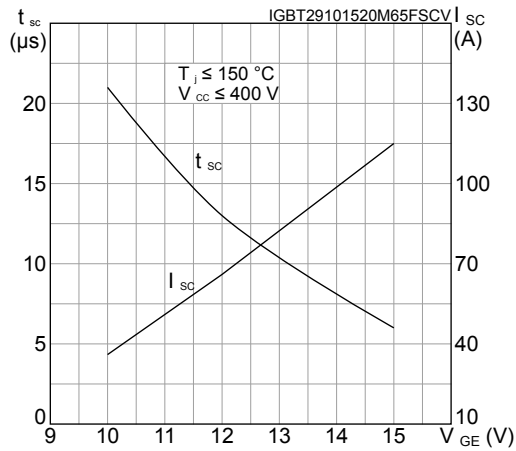

Figure 20. Switching times vs collector current

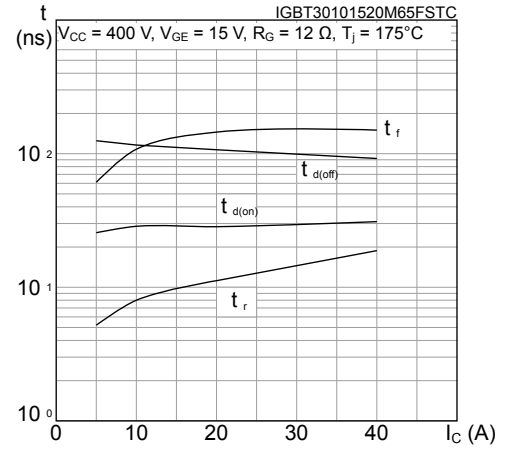

Figure 21. Switching times vs gate resistance

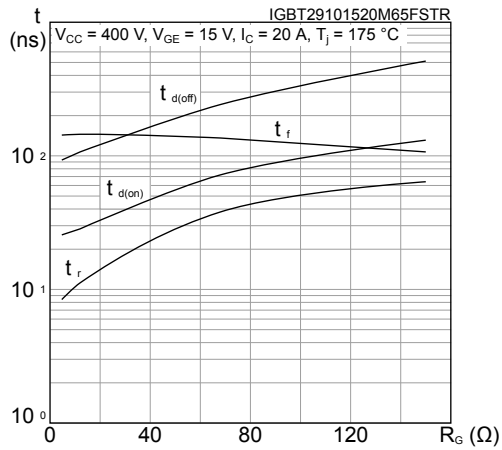

Figure 22. Reverse recovery current vs diode current slope

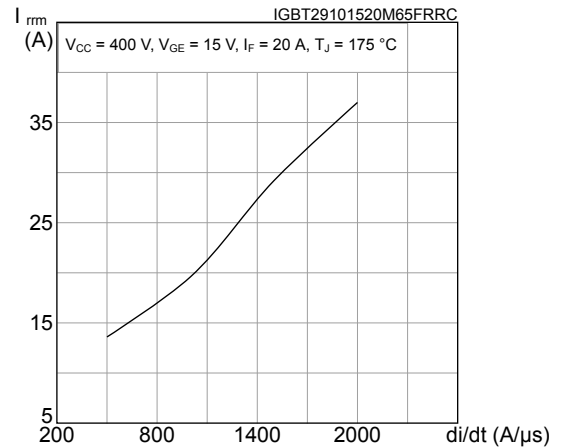

Figure 23. Reverse recovery time vs diode current slope

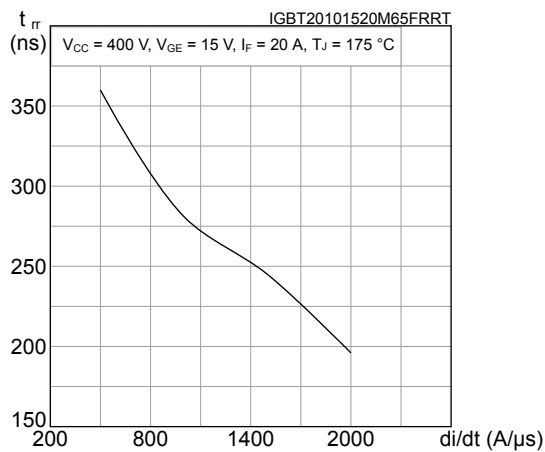

Figure 24. Reverse recovery charge vs diode current slope

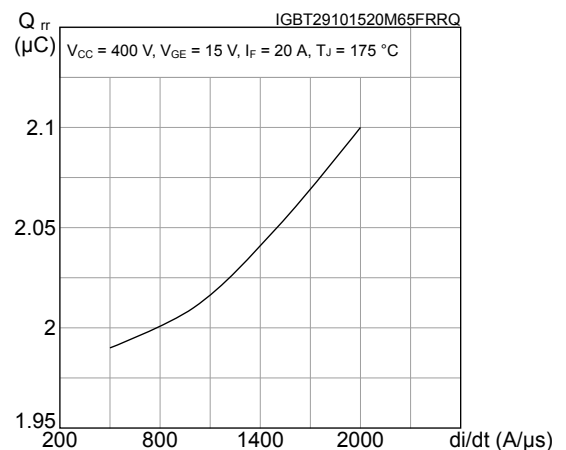

Figure 25. Reverse recovery energy vs diode current slope

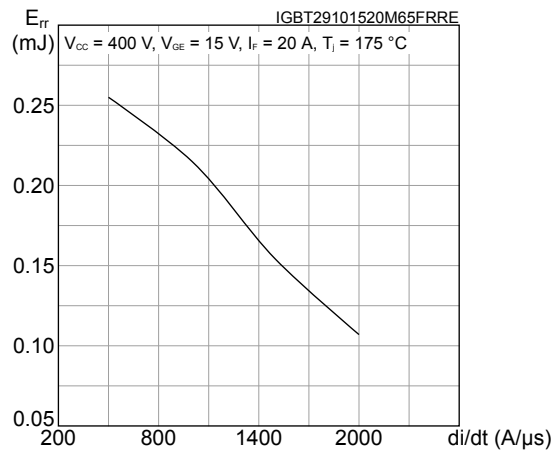

Figure 26. Thermal impedance for IGBT

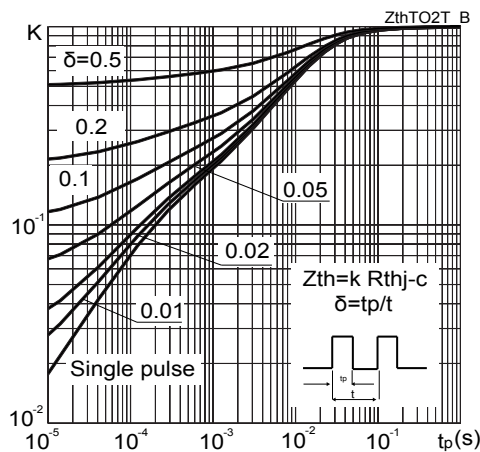
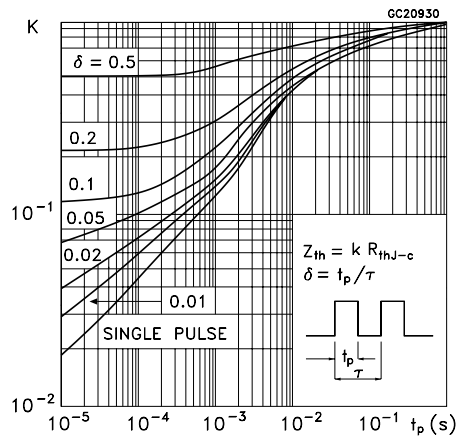
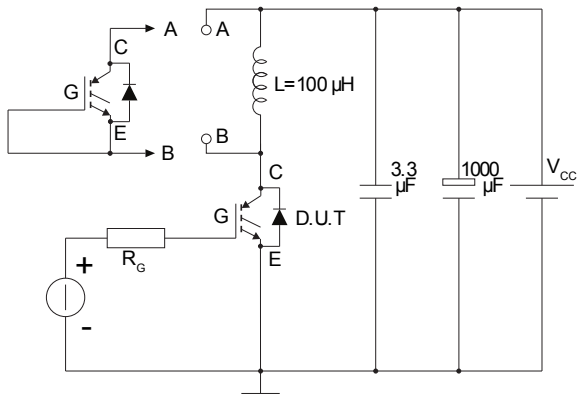

Figure 27. Thermal impedance for diode



3 Test circuits

Figure 28. Test circuit for inductive load switching

AM01504v1

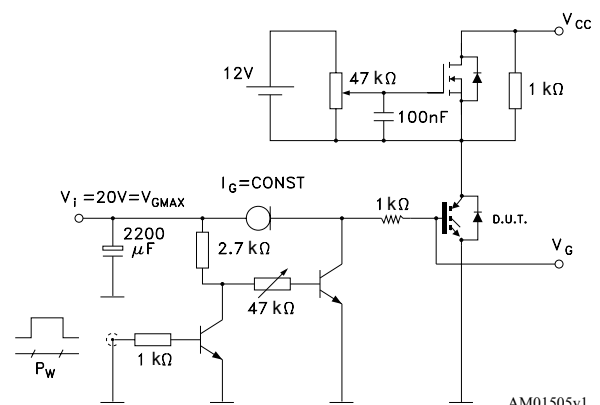
Figure 29. Gate charge test circuit

AM01505v1

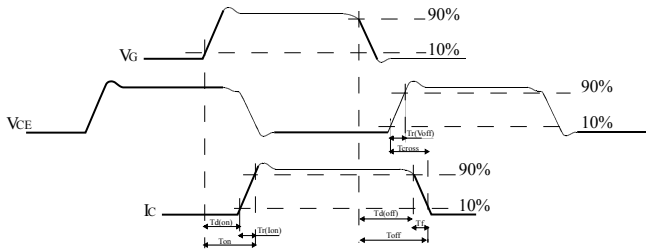
Figure 30. Switching waveform

AM01506v1

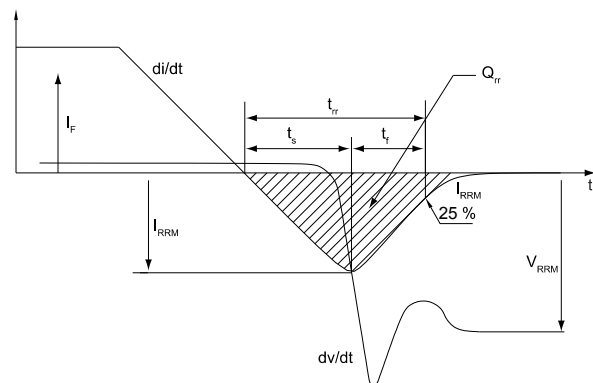
Figure 31. Diode reverse recovery waveform

AM01507v1

4 Package information

In order to meet environmental requirements, ST offers these devices in different grades of **ECOPACK®** packages, depending on their level of environmental compliance. ECOPACK® specifications, grade definitions and product status are available at: www.st.com. ECOPACK® is an ST trademark.

4.1 TO-220 type A package information

Figure 32. TO-220 type A package outline

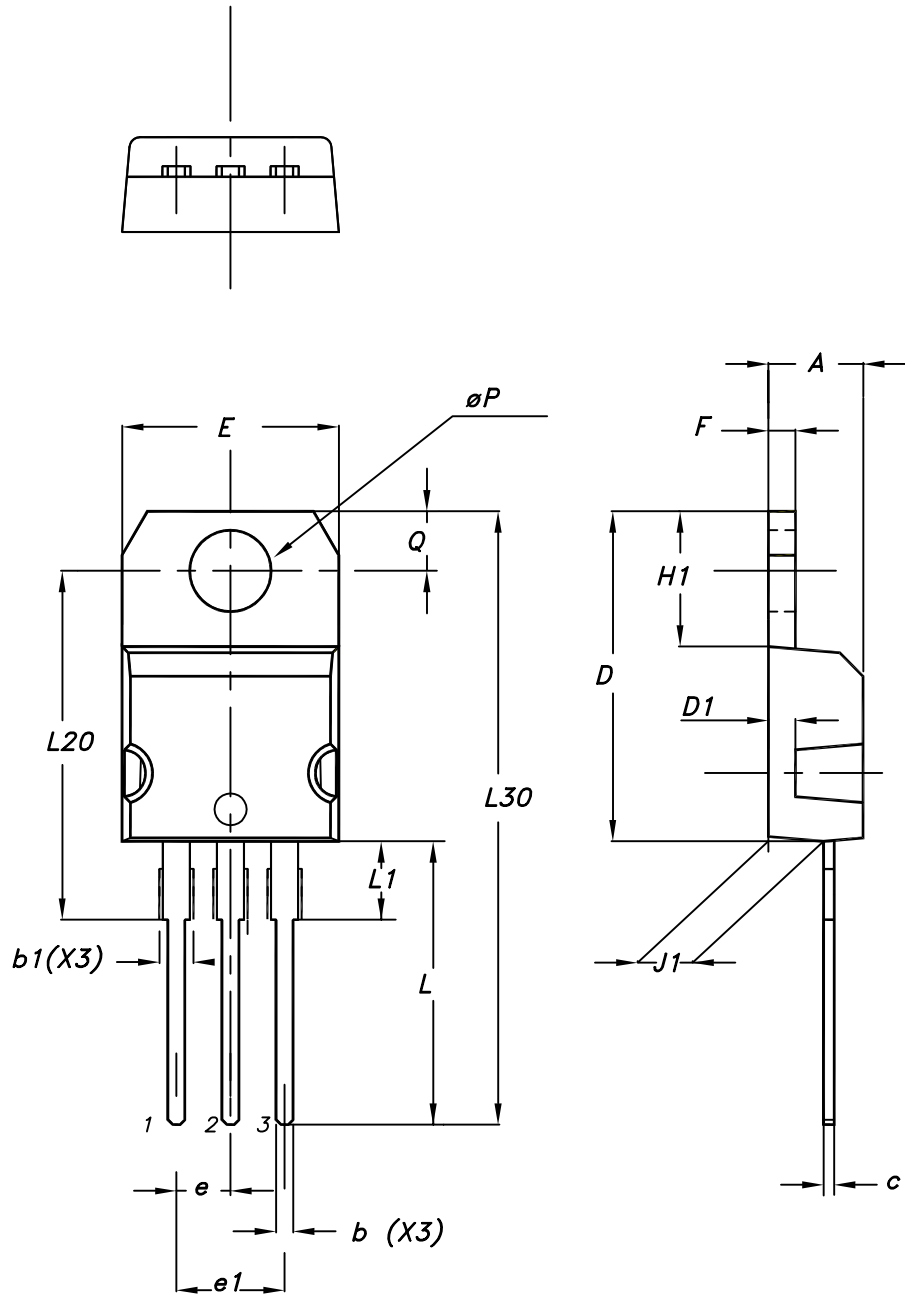

0015988_typeA_Rev_21

Table 7. TO-220 type A package mechanical data

| Dim. | mm | | |
|------|-------|-------|-------|
| | Min. | Typ. | Max. |
| A | 4.40 | | 4.60 |
| b | 0.61 | | 0.88 |
| b1 | 1.14 | | 1.55 |
| c | 0.48 | | 0.70 |
| D | 15.25 | | 15.75 |
| D1 | | 1.27 | |
| E | 10.00 | | 10.40 |
| e | 2.40 | | 2.70 |
| e1 | 4.95 | | 5.15 |
| F | 1.23 | | 1.32 |
| H1 | 6.20 | | 6.60 |
| J1 | 2.40 | | 2.72 |
| L | 13.00 | | 14.00 |
| L1 | 3.50 | | 3.93 |
| L20 | | 16.40 | |
| L30 | | 28.90 | |
| øP | 3.75 | | 3.85 |
| Q | 2.65 | | 2.95 |

Revision history

Table 8. Document revision history

| Date | Revision | Changes |
|-------------|----------|---|
| 11-Nov-2015 | 1 | First release. |
| 18-Apr-2016 | 2 | Updated <i>Figure 13: "Normalized $V_{(BR)CES}$ vs. junction temperature "</i> . |
| 08-Oct-2018 | 3 | Updated Table 3. Static characteristics. Minor text changes |

Contents

| | | |
|------------|---|-----------|
| 1 | Electrical ratings | 2 |
| 2 | Electrical characteristics | 3 |
| 2.1 | Electrical characteristics (curves) | 5 |
| 3 | Test circuits | 10 |
| 4 | Package information | 11 |
| 4.1 | D²PAK (TO-263) type A package information | 11 |
| | Revision history | 14 |
| | Contents | 15 |

IMPORTANT NOTICE – PLEASE READ CAREFULLY

STMicroelectronics NV and its subsidiaries (“ST”) reserve the right to make changes, corrections, enhancements, modifications, and improvements to ST products and/or to this document at any time without notice. Purchasers should obtain the latest relevant information on ST products before placing orders. ST products are sold pursuant to ST’s terms and conditions of sale in place at the time of order acknowledgement.

Purchasers are solely responsible for the choice, selection, and use of ST products and ST assumes no liability for application assistance or the design of Purchasers’ products.

No license, express or implied, to any intellectual property right is granted by ST herein.

Resale of ST products with provisions different from the information set forth herein shall void any warranty granted by ST for such product.

ST and the ST logo are trademarks of ST. All other product or service names are the property of their respective owners.

Information in this document supersedes and replaces information previously supplied in any prior versions of this document.

© 2018 STMicroelectronics – All rights reserved