



BASIC FUNCTION AUDIO PROCESSOR

- ONE STEREO AND ONE MONO INPUTS
- MUTE FUNCTION (SOFTWARE AND HARDWARE) CONTROLLED
- VOLUME CONTROL IN 1dB STEP
- BASS AND TREBLE CONTROL IN 2dB STEP
- FULLY PROGRAMMABLE LOUDNESS CONTROL
- FOUR SPEAKER ATTENUATORS:
 - Independent attenuation control
 - Independent mute function
- ALL FUNCTIONS PROGRAMMABLE VIA I²C BUS

DESCRIPTION

The TDA7432 is a volume, tone (bass and treble) balance (Left/Right) processor for quality audio applications in car radio and Hi-Fi systems.

Control is accomplished by serial bus microprocessor interface.

The AC signal setting is obtained by resistor net-

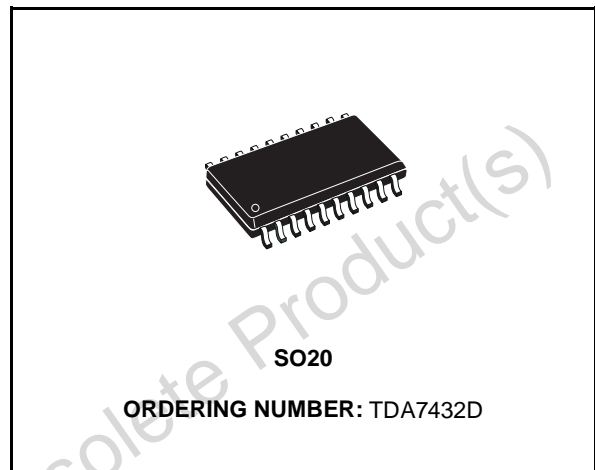

works and switches combined with operational amplifiers.

Thanks to the advanced BIPOLAR/CMOS Technology, the external components have been reduced.

BLOCK DIAGRAM

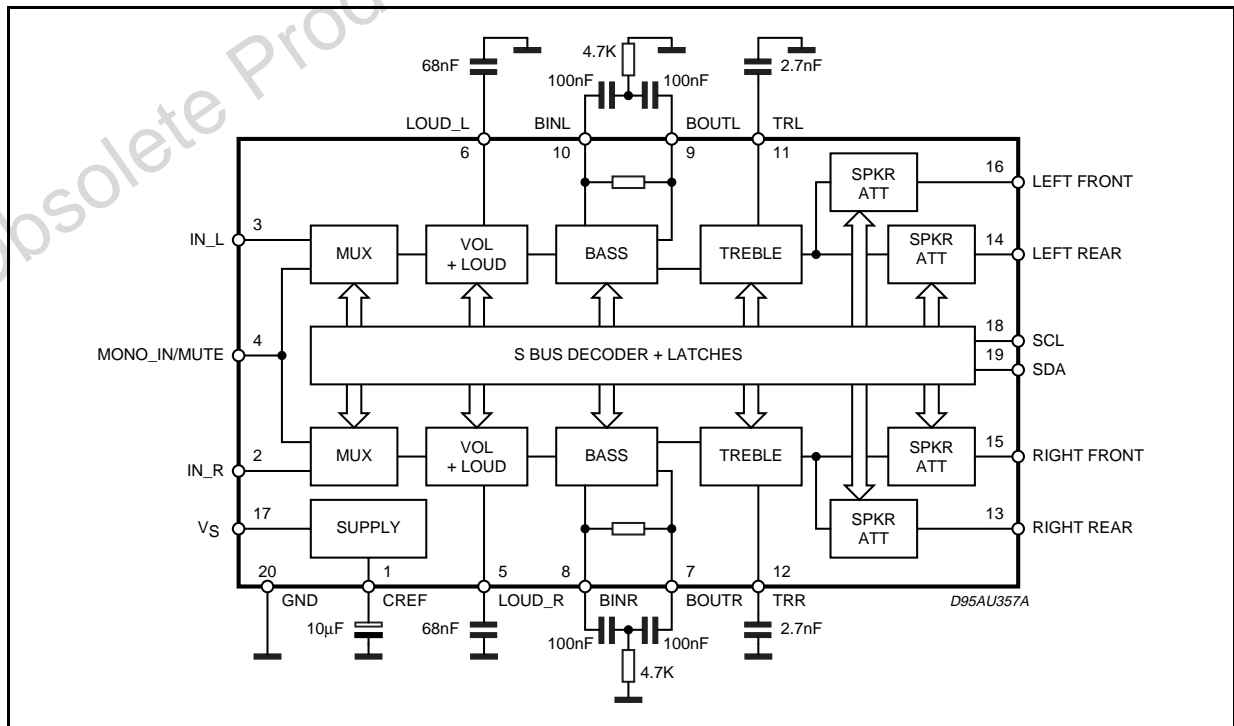

TDA7432

ABSOLUTE MAXIMUM RATINGS

| Symbol | Parameter | Value | Unit |
|-----------|-----------------------------|-------------|------|
| V_S | Operating Supply Voltage | 10.2 | V |
| T_{amb} | Operating Temperature Range | -40 to 85 | °C |
| T_{stg} | Storage Temperature Range | -55 to +150 | °C |

QUICK REFERENCE DATA

| Symbol | Parameter | Min. | Typ. | Max. | Unit |
|----------|---|-------|------|------|------------------|
| V_S | Supply Voltage | 7 | 9 | 10.2 | V |
| V_{CL} | Max. Input Signal Handling | 1.3 | 1.6 | | V _{rms} |
| THD | Total Harmonic Distortion ($V = 1V_{rms}$ $f = 1kHz$) | | 0.05 | | % |
| S/N | Signal to Noise Ratio | | 102 | | dB |
| S_c | Channel Separation $f = 1kHz$ | | 100 | | dB |
| | Volume Control 1dB step | -79 | | +32 | dB |
| | Bass Control 2dB step | -18 | | +18 | dB |
| | Treble Control 2dB step | -14 | | +14 | dB |
| | Speaker Attenuators | -37.5 | | 0 | dB |
| | Mute Attenuation | | 100 | | dB |

PIN CONNECTION (Top View)

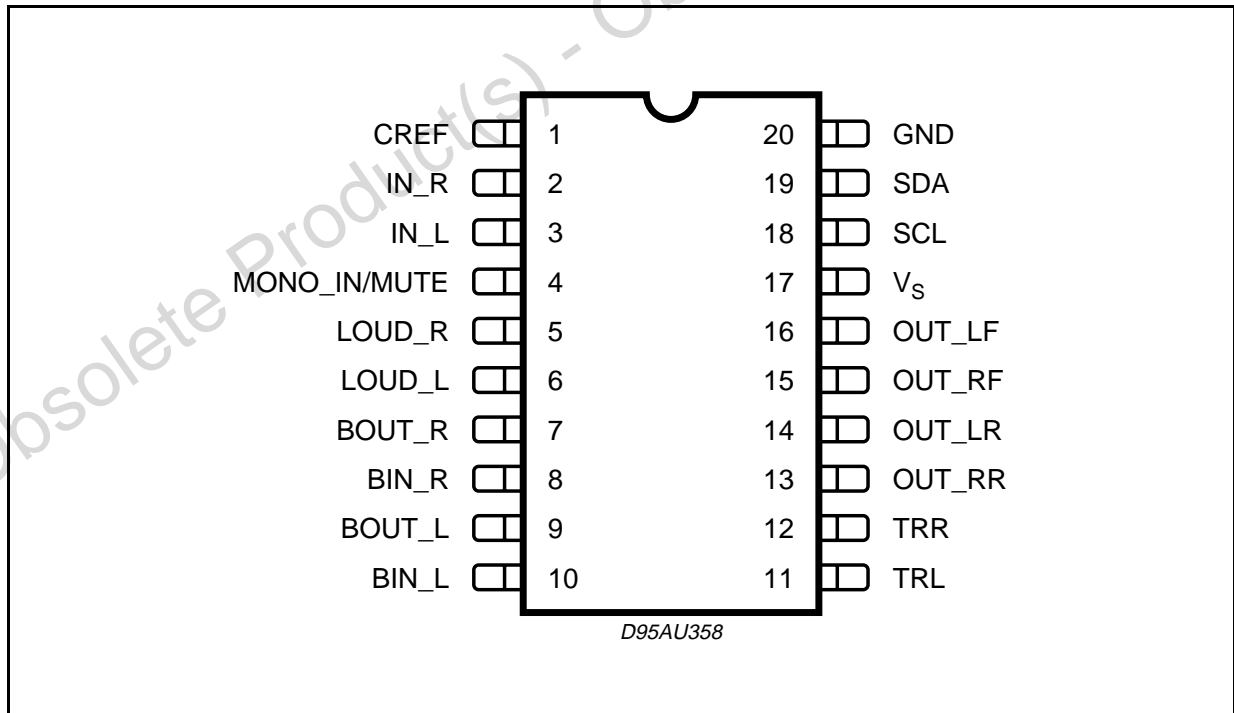

THERMAL DATA

| Symbol | Parameter | Value | Unit |
|------------------|----------------------------------|----------|------|
| $R_{th\ j-pins}$ | Thermal Resistance Junction-pins | Max. 150 | °C/W |

APPLICATION CIRCUIT

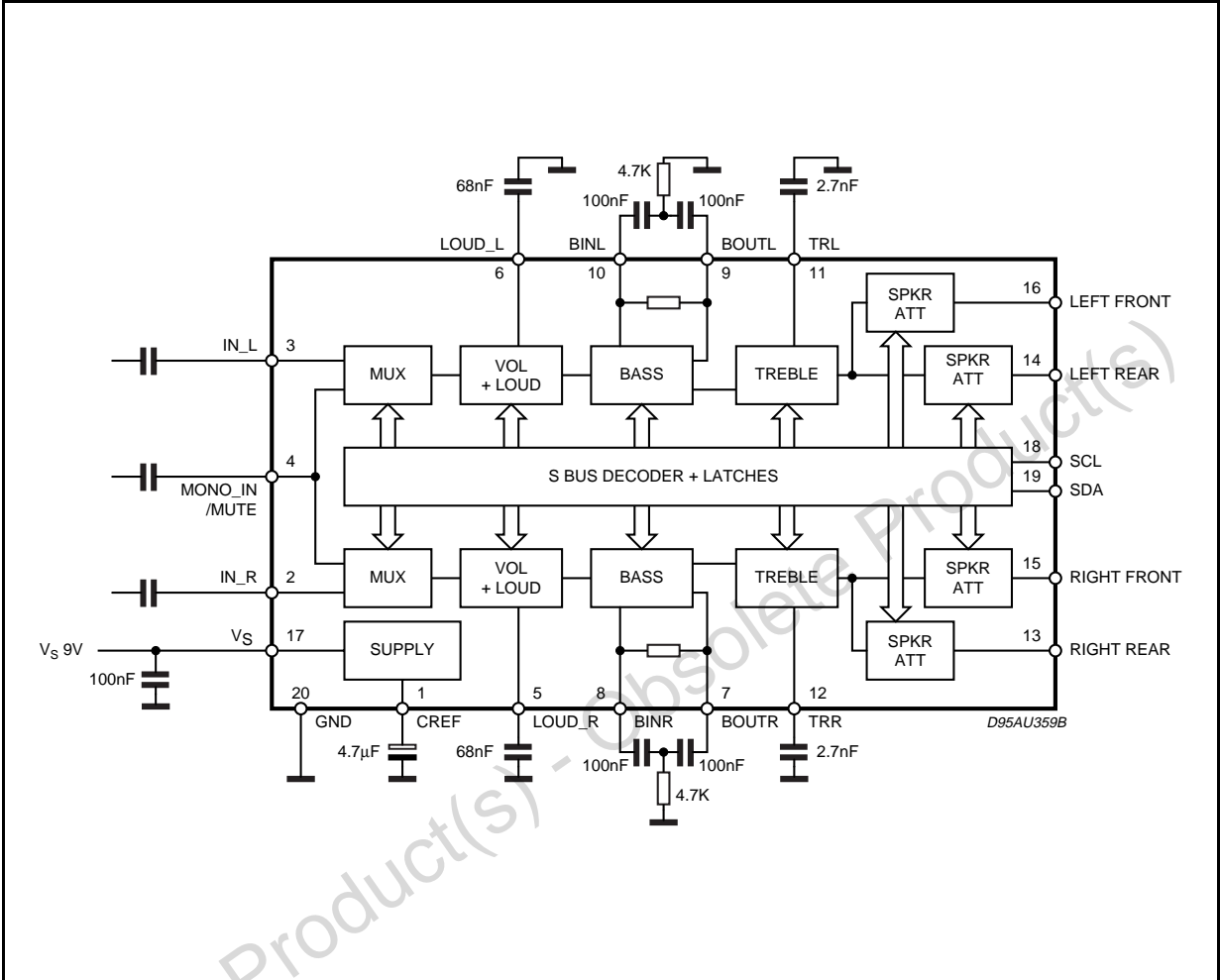

Obsolete Product(s) - Obsolete Product(s)

TDA7432

ELECTRICAL CHARACTERISTICS ($T_{amb} = 25^{\circ}\text{C}$, $V_S = 9\text{V}$, $R_L = 10\text{k}\Omega$, $R_g = 50\Omega$, all variable gains = 0dB, $f = 1\text{kHz}$, unless otherwise specified.)

| Symbol | Parameter | Test Condition | Min. | Typ. | Max. | Unit |
|-----------------------------|------------------------------|---|----------|----------|----------|------------------|
| INPUT SELECTOR | | | | | | |
| R_{IN} | Input Resistance | | 70 | 100 | 130 | $\text{k}\Omega$ |
| V_{CL} | Clipping Level | $d \leq 0.3\%$ | 1.3 | 1.6 | | V _{rms} |
| S_{IN} | Input Separation | | 70 | 100 | | dB |
| A_{MUTE} | Input Mute Attenuation | | 70 | 95 | | dB |
| V_{DC} | Mute DC Step | | | 0.2 | 10 | mV |
| MUTE AT AM INPUT (*) | | | | | | |
| V_{IL} | Input Low Voltage | AM not selected | | | 0.4 | V |
| VOLUME CONTROL | | | | | | |
| G_{MAX} | Max. Gain | Note 2 | 30.5 | 32 | 33.5 | dB |
| A_{MAX} | Max Attenuation | | 75 | 79 | 83 | dB |
| A_{step} | Step Resolution | | 0.5 | 1 | 1.5 | dB |
| E_A | Attenuation Set Error | $G = +20$ to -20dB | -1 | 0 | +1 | dB |
| | | $G = -20$ to -60dB | -2 | | 2 | dB |
| E_T | Tracking Error | $G = -20$ to -60dB | | | 2 | dB |
| V_{DC} | DC Steps | Adjacent Attenuation Steps, Range from 0 to -79dB | | 0.1 | 4 | mV |
| | | From 0dB to -79dB | | 0.5 | 10 | mV |
| LOUDNESS CONTROL | | | | | | |
| A_{MAX} | Control Range | | 14 | 15 | 16 | dB |
| A_{step} | Step Resolution | | 0.5 | 1 | 1.5 | dB |
| R_{LOUD} | Internal Resistor | | 37 | 50 | 63 | $\text{k}\Omega$ |
| BASS CONTROL | | | | | | |
| B_{RANGE} | Max. Bass boost | | 15.5 | 18 | 20 | dB |
| B_{CUT} | Max. Bass cut | | -20 | -18 | -15.5 | dB |
| A_{step} | Step Resolution | | 1 | 2 | 3 | dB |
| R_B | Internal Feedback Resistance | | 48 | 65 | 82 | $\text{k}\Omega$ |
| TREBLE CONTROL | | | | | | |
| C_{RANGE} | Control Range | | ± 13 | ± 14 | ± 15 | dB |
| A_{step} | Step Resolution | | 1 | 2 | 3 | dB |
| SPEAKER ATTENUATORS | | | | | | |
| C_{RANGE} | Control Range | | 36 | 37.5 | 39 | dB |
| A_{step} | Step Resolution | From 0 to -24dB | 0.5 | 1 | 1.5 | dB |
| A_{MUTE} | Output Mute Attenuation | | 70 | 90 | | dB |
| E_A | Attenuation Set Error | From 0 to -24dB | | | 1 | dB |
| V_{DC} | DC Steps | Adjacent Attenuation Steps | | 0.1 | 4 | mV |
| AUDIO OUTPUTS | | | | | | |
| V_{CLIP} | Clipping Level | $d = 0.3\%$ | 2 | 2.5 | | V _{rms} |
| G_{OUT} | Output Gain (fixed) | | | 4 | | dB |
| R_L | Output Load Resistance | AC - connected | 3 | | | $\text{k}\Omega$ |
| | | DC connected to GND | 5 | | | |
| C_L | Output Load Capacitance | | | | 10 | nF |
| R_{OUT} | Output Impedance | | | 30 | 100 | Ω |
| V_{DC} | DC Voltage Level | | 3.7 | 4 | 4.3 | V |

(*) The mute function can be activated without using the I2C bus by grounding the AM input when AM is not selected. This causes the input multiplexer to select the reference voltage instead of an input signal.

ELECTRICAL CHARACTERISTICS (continued)

| Symbol | Parameter | Test Condition | Min. | Typ. | Max. | Unit |
|-------------------|-----------------------------------|---|------|-----------------|--------|----------------|
| GENERAL | | | | | | |
| V _S | Supply Voltage | | 6 | 9 | 10.2 | V |
| I _S | Supply Current | | 5 | 8 | 11 | mA |
| PSRR | Power Supply Rejection Ratio | | 65 | 80 | | dB |
| e _{NO} | Output Noise | 20Hz - 20kHz "A" - weighted BW = 200Hz - 20kHz, flat output muted | | 4 7.0 5.5 | 20 | μV μV μV |
| S/N | Signal to Noise Ratio | all gains = 0dB; V _O = 1Vrms | | 103 | | dB |
| d | Distortion | V _{OUT} = 1Vrms | | 0.05 | 0.15 | % |
| Sc | Channel Separation | | 70 | 80 | | dB |
| E _T | Total Tracking Error | A _V = 0 to -20dB A _V = -20 to -60dB | | 0 0 | 1 2 | dB dB |
| BUS INPUTS | | | | | | |
| V _{IL} | Input Low Voltage | | | | 1 | V |
| V _{IH} | Input High Voltage | | 3 | | | V |
| I _{IN} | Input Current | V _{IN} = 0.4V | -5 | | +5 | μA |
| V _O | Output Voltage SDA Acknowledge | I _O = 1.6mA | | 0.15 | 0.4 | V |

SOFTWARE SPECIFICATION**Interface Protocol**

The interface protocol comprises:

- a start condition (S)
- a chip address byte (the LSB bit determines read / write transmission)
- a subaddress byte
- a sequence of data (N-bytes + acknowledge)
- a stop condition (P)

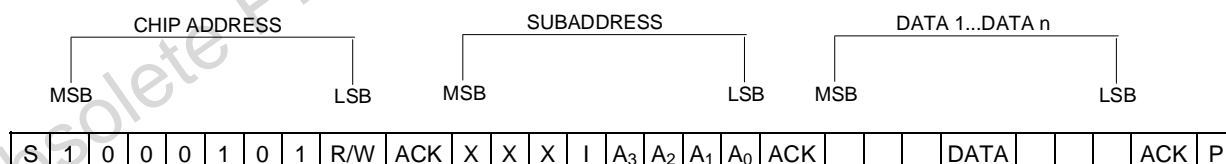

ACK = Acknowledge

S = Start

P = Stop

MAX CLOCK SPEED 500kbits/s

Auto Increment

If bit I in the subaddress byte is set to "1", the autoincrement of the subaddress is enabled.

TDA7432

SUBADDRESS (receive mode)

| MSB | | | | LSB | | | | FUNCTION |
|-----|---|---|---|-----|----|----|----|-----------------------|
| X | X | X | I | A3 | A2 | A1 | A0 | |
| | | | | 0 | 0 | 0 | 0 | Input selector |
| | | | | 0 | 0 | 0 | 1 | Volume |
| | | | | 0 | 0 | 1 | 0 | Bass, Treble |
| | | | | 0 | 0 | 1 | 1 | Speaker attenuator LF |
| | | | | 0 | 1 | 0 | 0 | Speaker attenuator LR |
| | | | | 0 | 1 | 0 | 1 | Speaker attenuator RF |
| | | | | 0 | 1 | 1 | 0 | Speaker attenuator RR |
| | | | | 0 | 1 | 1 | 1 | Loudness |

I = Auto increment

X = Not used

DATA BYTE SPECIFICATION

X = not relevant; set to "1" during testing

Input Selector

| MSB | | | | LSB | | | | FUNCTION |
|-----|----|----|----|-----|----|----|----|---------------------------------------|
| D7 | D6 | D5 | D4 | D3 | D2 | D1 | D0 | |
| | | | | | 0 | 0 | 0 | IN |
| | | | | | 0 | 0 | 1 | not used |
| | | | | | 0 | 1 | 0 | mono |
| | | | | | 0 | 1 | 1 | no input selected |
| | | | | | 1 | X | X | mute (low homic) |
| | | | | 0 | | | | non-symmetrical bass cut (note 1) |
| | | | | 1 | | | | symmetrical bass cut |
| | | | 0 | | | | | extended bass range |
| | | | 1 | | | | | standard bass range $\pm 14\text{dB}$ |

For example to select the MONO input the Data Byte is: X X X X 0 1 0.

An additional direct mute function is included in the Speaker Attenuators.

Note 1: Bass cut for very low frequencies.

| MSB | | | | LSB | | | | VOLUME |
|-------|----|----|----|-----|----|----|----|--------|
| D7(*) | D6 | D5 | D4 | D3 | D2 | D1 | D0 | |
| 1 | 0 | 0 | 0 | | | | | +32dB |
| 1 | 0 | 0 | 1 | | | | | +16dB |
| 1 | 0 | 1 | 0 | | | | | 0dB |
| 1 | 0 | 1 | 1 | | | | | -16dB |
| 1 | 1 | 0 | 0 | | | | | -32dB |
| 1 | 1 | 0 | 1 | | | | | -48dB |
| 1 | 1 | 1 | 0 | | | | | -64dB |
| 1 | | | | 0 | 0 | 0 | 0 | 0dB |
| 1 | | | | 0 | 0 | 0 | 1 | -1dB |
| 1 | | | | 0 | 0 | 1 | 0 | -2dB |
| 1 | | | | 1 | 1 | 1 | 1 | -15dB |

(*) Loudness = ON

Note 2:

It is not recommended to use a gain more than 20dB for system performance reason. In general, the max. gain should be limited by software to the maximum value, which is needed for the system.

Bass, Treble

| | MSB | | | | LSB | | | | FUNCTION |
|-------------------|-----|----|----|----|-----|----|----|----|--------------|
| | D7 | D6 | D5 | D4 | D3 | D2 | D1 | D0 | |
| | | | | | 0 | 0 | 0 | 0 | Treble Steps |
| | | | | | 0 | 0 | 0 | 1 | -14dB |
| | | | | | 0 | 0 | 1 | 0 | -12dB |
| | | | | | 0 | 0 | 1 | 1 | -10dB |
| | | | | | 0 | 1 | 0 | 0 | -8dB |
| | | | | | 0 | 1 | 0 | 1 | -6dB |
| | | | | | 0 | 1 | 1 | 0 | -4dB |
| | | | | | 0 | 1 | 1 | 1 | -2dB |
| | | | | | 1 | 1 | 1 | 1 | 0dB |
| | | | | | 1 | 1 | 1 | 0 | 0dB |
| | | | | | 1 | 1 | 0 | 1 | +2dB |
| | | | | | 1 | 1 | 0 | 0 | +4dB |
| | | | | | 1 | 0 | 1 | 1 | +6dB |
| | | | | | 1 | 0 | 1 | 0 | +8dB |
| | | | | | 1 | 0 | 0 | 1 | +10dB |
| | | | | | 1 | 0 | 0 | 1 | +12dB |
| | | | | | 1 | 0 | 0 | 0 | +14dB |
| D4 Input Selector | | | | | | | | | |
| | | | | | | | | | Bass Steps |
| 0 | 0 | 0 | 0 | 1 | | | | | -18dB |
| 0 | 0 | 0 | 0 | 0 | | | | | -16dB |
| 1 | 0 | 0 | 0 | 0 | | | | | -14dB |
| 1 | 0 | 0 | 0 | 1 | | | | | -12dB |
| 1 | 0 | 0 | 1 | 0 | | | | | -10dB |
| 1 | 0 | 0 | 1 | 1 | | | | | -8dB |
| 1 | 0 | 1 | 0 | 0 | | | | | -6dB |
| 1 | 0 | 1 | 0 | 1 | | | | | -4dB |
| 1 | 0 | 1 | 1 | 0 | | | | | -2dB |
| 1 | 0 | 1 | 1 | 1 | | | | | 0dB |
| 1 | 1 | 1 | 1 | 1 | | | | | 0dB |
| 1 | 1 | 1 | 1 | 0 | | | | | +2dB |
| 1 | 1 | 1 | 0 | 1 | | | | | +4dB |
| 1 | 1 | 1 | 0 | 0 | | | | | +6dB |
| 1 | 1 | 0 | 1 | 1 | | | | | +8dB |
| 1 | 1 | 0 | 1 | 0 | | | | | +10dB |
| 1 | 1 | 0 | 0 | 1 | | | | | +12dB |
| 1 | 1 | 0 | 0 | 0 | | | | | +14dB |
| 0 | 1 | 0 | 0 | 0 | | | | | +16dB |
| 0 | 1 | 0 | 0 | 1 | | | | | +18dB |

For example 12dB Treble and -8dB Bass give the following DATA BYTE: 0 0 1 1 1 0 0 1

Speaker Attenuators

| MSB | | | | LSB | | | | SPEAKER ATTENUATOR LF, LR, RF, RR |
|-----|----|----|----|-----|----|----|----|-----------------------------------|
| D7 | D6 | D5 | D4 | D3 | D2 | D1 | D0 | |
| X | X | 0 | 0 | 0 | 0 | 0 | 0 | 0dB |
| X | X | 0 | 0 | 0 | 0 | 0 | 1 | -1dB |
| | | | : | | | | | : |
| X | X | 0 | 1 | 1 | 0 | 0 | 0 | -24dB |
| X | X | 0 | 1 | 1 | 0 | 0 | 1 | -25.5dB |
| X | X | 0 | 1 | 1 | 0 | 1 | 0 | -27dB |
| X | X | 0 | 1 | 1 | 0 | 1 | 1 | -28.5dB |
| X | X | 0 | 1 | 1 | 1 | 0 | 0 | -30dB |
| X | X | 0 | 1 | 1 | 1 | 1 | 1 | -32dB |
| X | X | 0 | 1 | 1 | 1 | 1 | 0 | -34.5dB |
| X | X | 0 | 1 | 1 | 1 | 1 | 1 | -37.5dB |
| | | | | | | 1 | | |
| X | X | 1 | X | X | X | X | X | Speaker Mute |



Loudness

| MSB | | | | | | | LSB | | LOUDNESS |
|-----|----|----|----|----|----|----|-----|------------------------|----------|
| D7 | D6 | D5 | D4 | D3 | D2 | D1 | D0 | | |
| X | X | X | 0 | 0 | 0 | 0 | 0 | 0dB | |
| X | X | X | 0 | 0 | 0 | 0 | 1 | -1dB | |
| X | X | X | 0 | 0 | 0 | 1 | 0 | -2dB | |
| X | X | X | 0 | 0 | 0 | 1 | 1 | -3dB | |
| X | X | X | 0 | 0 | 1 | 0 | 0 | -4dB | |
| X | X | X | 0 | 0 | 1 | 0 | 1 | -5dB | |
| X | X | X | 0 | 0 | 1 | 1 | 0 | -6dB | |
| X | X | X | 0 | 0 | 1 | 1 | 1 | -7dB | |
| X | X | X | 0 | 1 | 0 | 0 | 0 | -8dB | |
| X | X | X | 0 | 1 | 0 | 0 | 1 | -9dB | |
| X | X | X | 0 | 1 | 0 | 1 | 0 | -10dB | |
| X | X | X | 0 | 1 | 0 | 1 | 1 | -11dB | |
| X | X | X | 0 | 1 | 1 | 0 | 0 | -12dB | |
| X | X | X | 0 | 1 | 1 | 0 | 1 | -13dB | |
| X | X | X | 0 | 1 | 1 | 1 | 0 | -14dB | |
| X | X | X | 0 | 1 | 1 | 1 | 1 | -15dB | |
| X | X | X | 1 | D3 | D2 | D1 | D0 | Loudness flat (Note 3) | |

For example to select -14dB Loudness the Data Byte is : X X X 0 1 1 1 0.

Note3:

Fiat attenuation, according to the selected byte. The loudness can be completely disabled by setting bit D7 in the volume byte to "0". In this case the attenuation is 0dB independent from the loudness settings.

Functional Description

The input selector is able to select 1 stereo inputs and 1 mono input (AM). The inputs are DC biased with 100kΩ resistors to the internal reference voltage of 3V. The AM input can be use additionally as hardware mute pin. If this pin is pulled to ground by an external transistor and AM is not selected, the input selector mutes the input (reference voltage selected). The AM part is considered to be switched OFF. If the output of the AM part is not high ohmic in this condition, a series resistor of about 20kΩ has to be foreseen.

The volume control can be programmed from a gain of +32dB to an attenuation of -79dB in 1dB steps. The maximum gain should be kept as low as possible for system performance reason. It has to be limited by software to the absolute necessary system gain, depending on the signal source level and the power amplifier gain.

The bass control acts in a range from +18dB to -18dB in 2dB steps. The filter response is deter-

mined by the external filter components. An extensive simulation software is available in order to support the design of the bass filter response with different filter configurations.

The extended bass boost range of +18dB allows the implementation of the software loudness function by additional bass and treble boost.

The treble control acts in a range of ±14dB in 2dB steps. The external capacitor determines with the internal resistor of 50kΩ the corner frequency of the treble response.

The four speaker attenuators can be controlled independently from 0 to -37.5dB, which allows the implementation of balance and fader a the four speaker system. The attenuation steps size is 1 db from 0 to -24dB and increases nonlinearly up to the maximum attenuation of 37.5dB. A special mute bit forces the speaker attenuator into the mute position.

All 4 outputs are low distortion push pull outputs, able to drive a load of 3kΩ.

| DIM. | mm | | | inch | | |
|------|--------------------|------|-------|-------|-------|-------|
| | MIN. | TYP. | MAX. | MIN. | TYP. | MAX. |
| A | 2.35 | | 2.65 | 0.093 | | 0.104 |
| A1 | 0.1 | | 0.3 | 0.004 | | 0.012 |
| B | 0.33 | | 0.51 | 0.013 | | 0.020 |
| C | 0.23 | | 0.32 | 0.009 | | 0.013 |
| D | 12.6 | | 13 | 0.496 | | 0.512 |
| E | 7.4 | | 7.6 | 0.291 | | 0.299 |
| e | | 1.27 | | | 0.050 | |
| H | 10 | | 10.65 | 0.394 | | 0.419 |
| h | 0.25 | | 0.75 | 0.010 | | 0.030 |
| L | 0.4 | | 1.27 | 0.016 | | 0.050 |
| K | 0° (min.)8° (max.) | | | | | |

OUTLINE AND MECHANICAL DATA

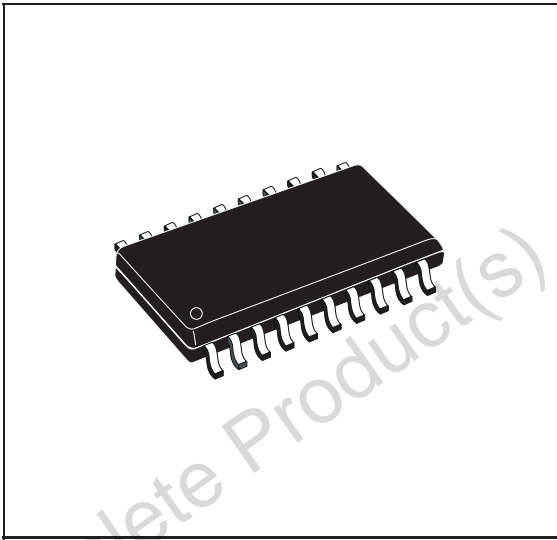

SO20

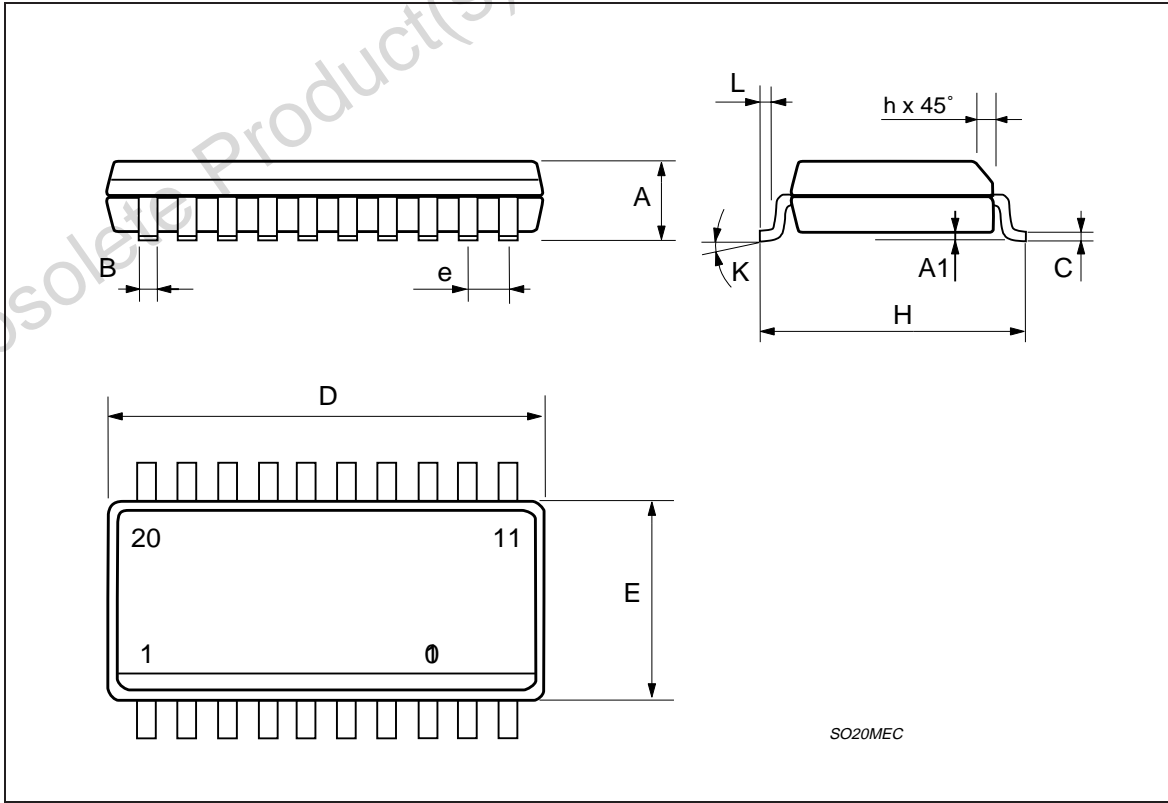

SO20MEC

Obsolete Product(s) - Obsolete Product(s)

Information furnished is believed to be accurate and reliable. However, STMicroelectronics assumes no responsibility for the consequences of use of such information nor for any infringement of patents or other rights of third parties which may result from its use. No license is granted by implication or otherwise under any patent or patent rights of STMicroelectronics. Specifications mentioned in this publication are subject to change without notice. This publication supersedes and replaces all information previously supplied. STMicroelectronics products are not authorized for use as critical components in life support devices or systems without express written approval of STMicroelectronics.

The ST logo is a registered trademark of STMicroelectronics.

All other names are the property of their respective owners

© 2003 STMicroelectronics - All rights reserved

STMicroelectronics GROUP OF COMPANIES

Australia – Belgium - Brazil - Canada - China – Czech Republic - Finland - France - Germany - Hong Kong - India - Israel - Italy - Japan - Malaysia - Malta - Morocco - Singapore - Spain - Sweden - Switzerland - United Kingdom - United States

www.st.com